

University of Nebraska - Lincoln

DigitalCommons@University of Nebraska - Lincoln

Tractor Maintenance Repair and Restoration

Tractor Test and Power Museum, The Lester F.
Larsen

January 1928

Catapillar 20 Test 150

Tractor Museum

University of Nebraska-Lincoln, TractorMuseumArchives@unl.edu

Follow this and additional works at: <https://digitalcommons.unl.edu/tractorpower>



Part of the [Applied Mechanics Commons](#)

Museum, Tractor, "Catapillar 20 Test 150" (1928). *Tractor Maintenance Repair and Restoration*. 4.
<https://digitalcommons.unl.edu/tractorpower/4>

This Article is brought to you for free and open access by the Tractor Test and Power Museum, The Lester F. Larsen at DigitalCommons@University of Nebraska - Lincoln. It has been accepted for inclusion in Tractor Maintenance Repair and Restoration by an authorized administrator of DigitalCommons@University of Nebraska - Lincoln.



**"CATERPILLAR"
TWENTY
TRACTOR.**

CATERPILLAR
REG. U.S. PAT. OFF.

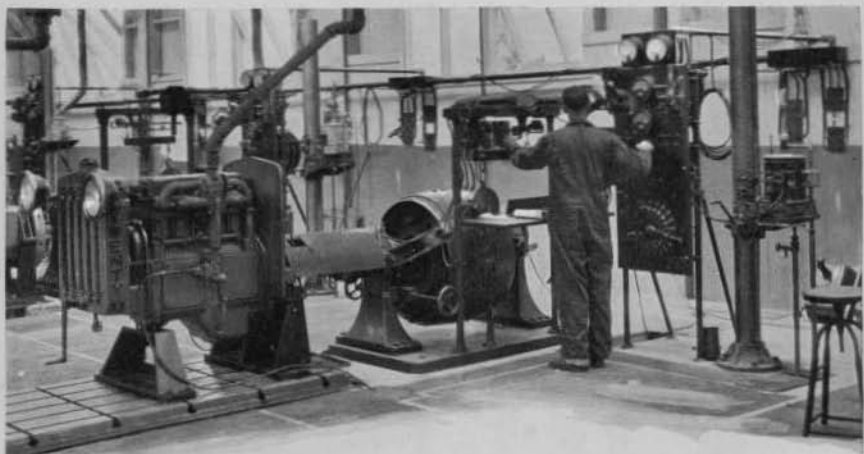

LABORATORY and field tests, exceeding in severity the most extreme actual service and equalling in duration many months of normal use, precede the public appearance of any "Caterpillar" model. Tractors wallow in deep mud; leap from runways to punish springs; air-cleaners are operated in clouds of powder-fine dust; engines are subjected to extreme over-loads; complete tractors are built and discarded. Every new "Caterpillar" model is time-tried and proven.





WITH the issuance of this catalog, a new size of the "Caterpillar" Tractor takes its place in the "Caterpillar" family. The Twenty is a new tractor—new in size, new in rating, new in price, new in that it embodies the latest accumulation of the many years of "Caterpillar" experience.

In a broader sense, the Twenty is not new—the knowledge behind it is that of the pioneers of track-type tractor design and construction—technical knowledge enriched by the practical experience of thousands of "Caterpillar" users throughout the world.

In the same broad sense, every model of the "Caterpillar" is always new. Each passing year finds the builders of the "Caterpillar" Tractor better armed to build better tractors. Refinements, changes of greater or less consequence are continually being made in all sizes of the "Caterpillar." If these changes were held in reserve it would be possible to announce "new models" of all the present "Caterpillar" sizes every two or three years. But the effort of the Caterpillar Tractor Co. to constantly better its products is a continuous one, and the fruits of that effort are promptly passed on to purchasers. Thus there is opportunity to present a really "new model" only when a "new size" is produced to broaden the "Caterpillar" line.

The Twenty enters the "Caterpillar" family, joining its brothers in doing the world's work *Better, Quicker, Cheaper.*

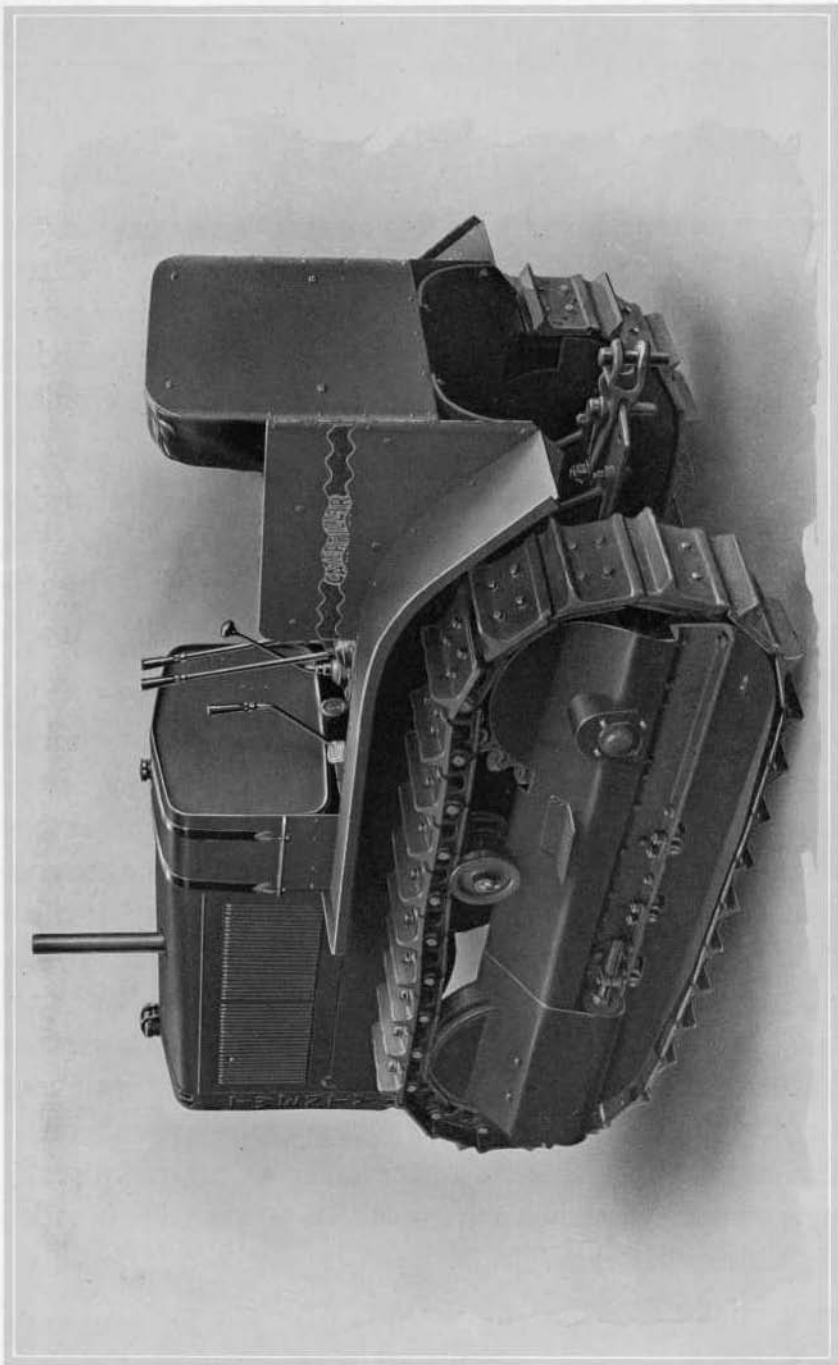

The "Caterpillar" Twenty Tractor.



Purchase of a "Caterpillar" Tractor is investment in the ability to do Better, Quicker, Cheaper work. The "Caterpillar" is powerful—and sure-gripping tracks make its power available when and where it is needed. The "Caterpillar" is dependable—and its amazing endurance assures a long life of dependable service. The "Caterpillar" is economical—its operating and upkeep costs are low—its records of accomplishment, low cost per horsepower hour, are unsurpassed.

These things mean much—

- when fields demand immediate plowing or planting;
- when a road contract must be completed on time;
- when logs are ready to be moved;
- when a big yardage of earth must be transported quickly;
- when industry demands lessened hauling costs;
- when there are heavy loads of any kind to haul through mud, sand or dust—up hill and down—over all kinds of roads or no roads at all.

Such performance is made possible by many unusual features of design, materials and construction, briefly described in the following pages.

For convenience, the Twenty is discussed under three general divisions: The Engine, or power-creating unit; the Transmission, or power-conveying unit; and the Track Assembly, or the unit which transforms power into accomplishment.

Because of the special interest attached to the traction principle employed in the "Caterpillar" Tractor, this feature of the Twenty is described first.

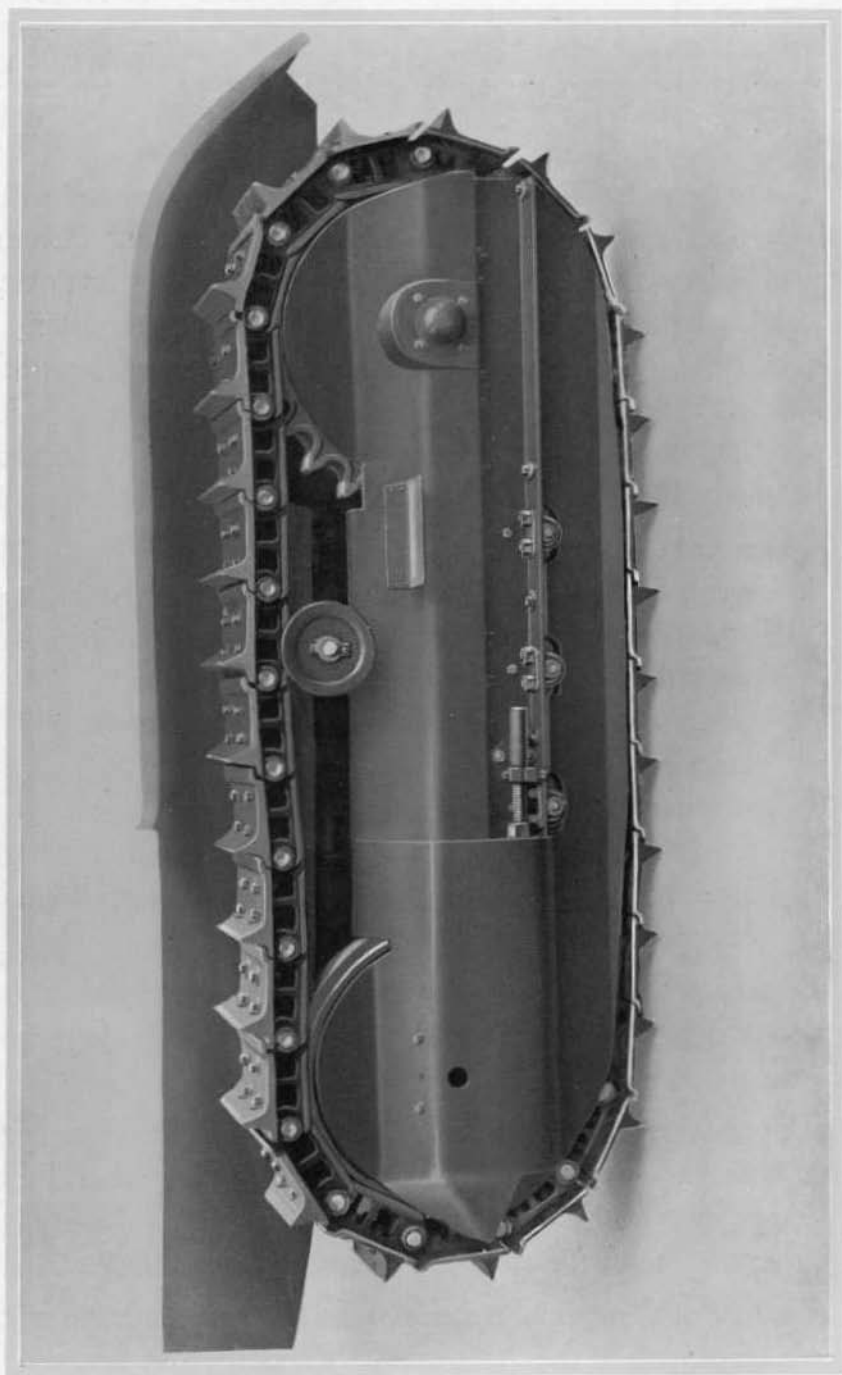

The Twenty Track Assembly—Note the completeness of the shidding.



Track Assembly

Track Roller Frames The track roller frames are of the single unit, oscillating type, made of heavy structural steel. They are fastened together by alloy steel bolts, making it easy for operators in the field to do repairing, should accidental damage occur. The frames are notable for their simplicity of design and are properly braced and held to correct alignment. A heavy angle brace connects each roller frame with the center of the sprocket shaft. It is practically impossible to damage the frames, except by the greatest abuse.

Both outer and center bearings at the rear of the track roller frame are very heavy castings, with large bearings on the axles. They are bored to an accurate fit. The center bearings are grooved inside to retain the grease. All are lubricated through standard Alemite connections.

Spring Equalizer An equalizer spring carries the weight of the front end of the tractor to the front part of the roller frames. It is a heavy, alloy steel, laminated spring that absorbs

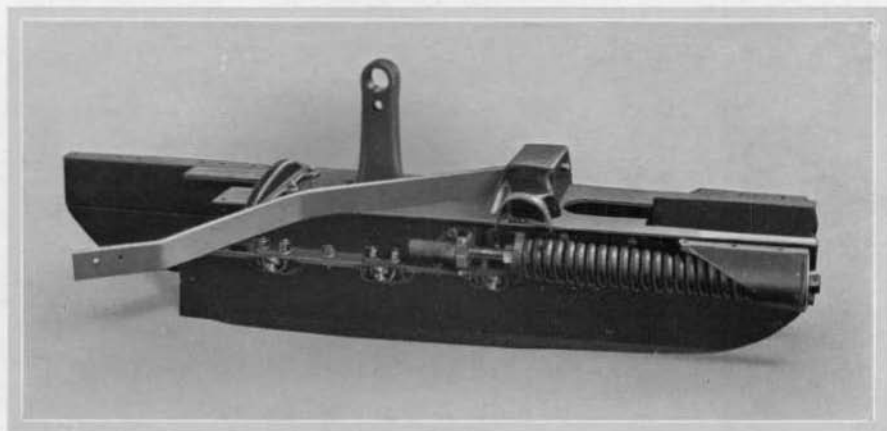

One of the Track Roller Frames, showing the track release spring, track carrier roller bracket, and the angle brace to the sprocket shaft.



the shocks and jars of rough travel and allows full oscillation of the track frame. The spring is held within correct oscillation limits by a supplementary leaf spring.

Idlers and Track Release The front idlers are one-piece, special-analysis steel castings, provided with spiral roller bearings and adequate dirt seals. They are mounted in sliding boxes which are positioned by alloy steel helical springs.

These springs are designed to maintain the idler in its normal position under all working conditions, but in the event that the track becomes clogged, the springs recoil, thereby allowing the idler to slide back and prevent undue strain upon the track roller frame and the track until the foreign material becomes dislodged. This feature provides a safety track release to prevent breakage which might otherwise occur.

The front idlers are easily adjustable to take up any slack or sag in the tracks.

Track Rollers The track rollers are of composite assembly, each roller consisting of a heavy grey iron hub with forged

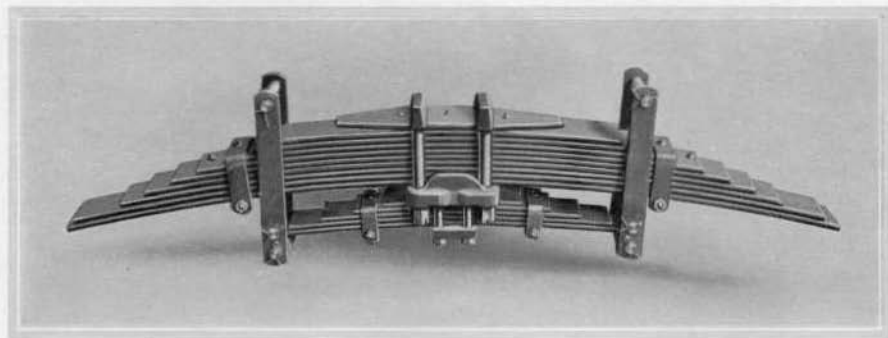

The Equalizer Spring and its supplementary oscillation-control spring.

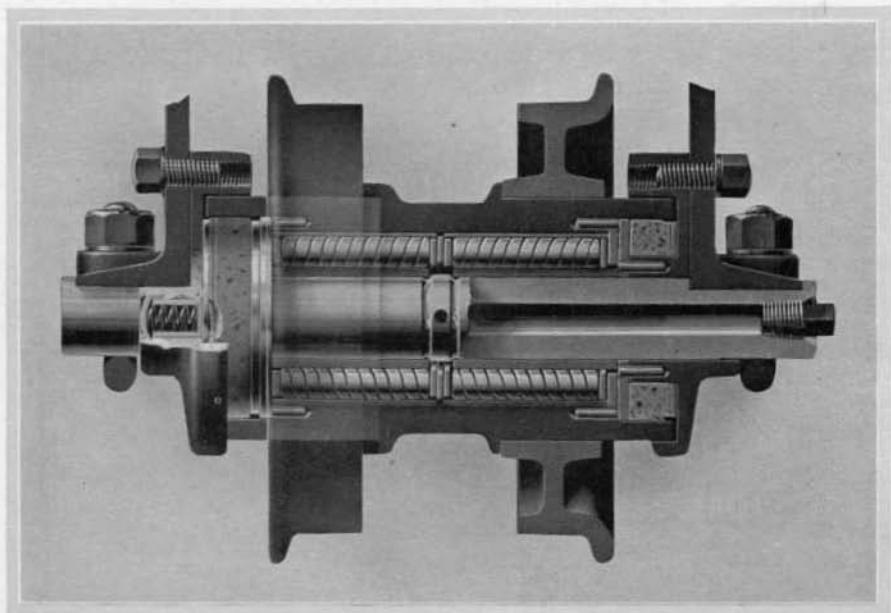

A sectional view of a Track Roller showing the anti-friction bearings and cork seal

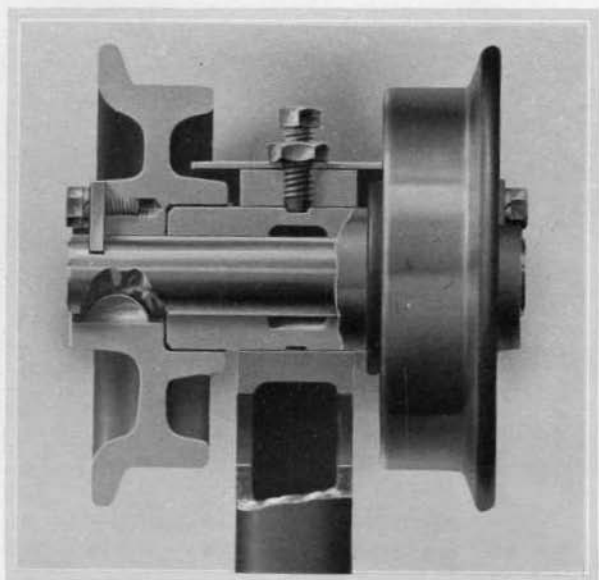

A sectional view of one of the Track Carrier Rollers. One of these rollers, on each side of the tractor, supports the upper side of the track. Note how the bearing and pin, though securely locked in place, are easily removable.



steel rim shrunk on. The roller assemblies run on large spiral roller bearings which are provided with adequate oil and dirt seals.

Track Carrier Roller A track carrier roller is mounted in a bracket on each side of the tractor. This roller supports the top of the track and keeps it in line.

Track Assembly Guards Sheet-steel guards cover and protect all parts of the track roller frame assembly from mud, dust and sand.

Track The Twenty track is of the built-up type, consisting of drop-forged steel shoes, bolted to drop-forged, heat-treated steel links by alloy steel bolts. The links are machined and are heat treated for maximum wear and strength; the links are assembled, in turn, with machined, carburized and hardened

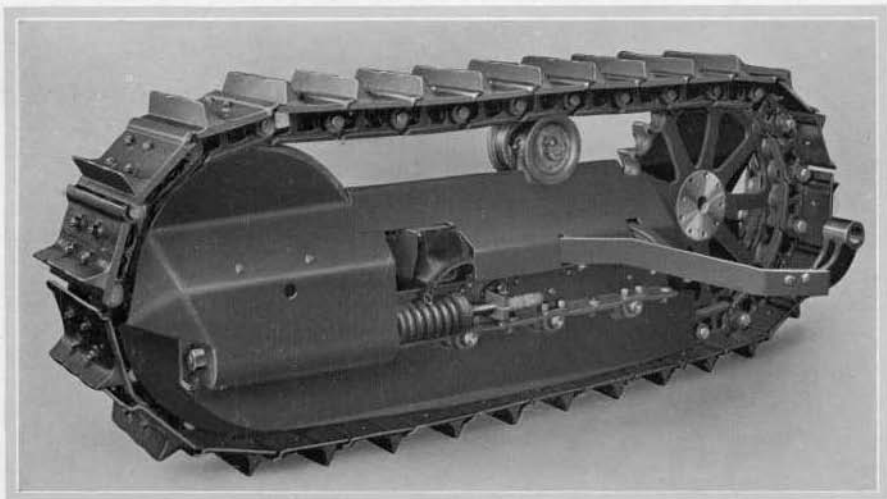

The inner side of the Track Assembly—Note that the inner as well as the outer side is thoroughly shielded.



steel track pin bushings, which are forced into place under heavy pressure.

Through the link bosses are forced the carburized and hardened steel pins. Bushings and pins are made with close fits and counterbored ends to prevent dust and dirt from entering and causing wear of the bearing surfaces.

To the links are bolted the track shoes. These shoes are steel drop forgings—the bolts that hold them to the links are of alloy steel, heat treated.

The great durability of the "Caterpillar" tracks is due largely to scientific heat treating of metals. For example, the links are each heat treated to give them the maximum strength and shock resistance, the rail surface of the link receiving further special heat treatment to give it maximum wear resistance. Each part of the track receives the special heat treatment necessary to give it the desired qualities. The results of this construction, together with scientific design, are remarkably long life and low upkeep.

Track Shoes The standard track shoes of the Twenty are eleven inches wide. The standard shoe is the right design to give best service and best results under a wide range of conditions. Other special shoes, grousers and plates are provided on special order.

The Twenty Engine

The Twenty power plant is of the four-cylinder, four-cycle, water-cooled, valve-in-head type, and is designed in every detail to withstand the most rigorous demands of tractor service.



Such service differs materially from that required of other automotive equipment. An automobile, for example, exerts its full power only when traveling at top speed or climbing steep grades, most of the time using only part of the power and operating under ideal road conditions.

The tractor, on the other hand, must handle a full load practically all the time, and frequently under the most difficult conditions. The "Caterpillar" engine is suited to such hard work.

Co-ordination The engine is all "Caterpillar" construction, with every detail carefully designed to co-ordinate properly with all other units in the assembly.

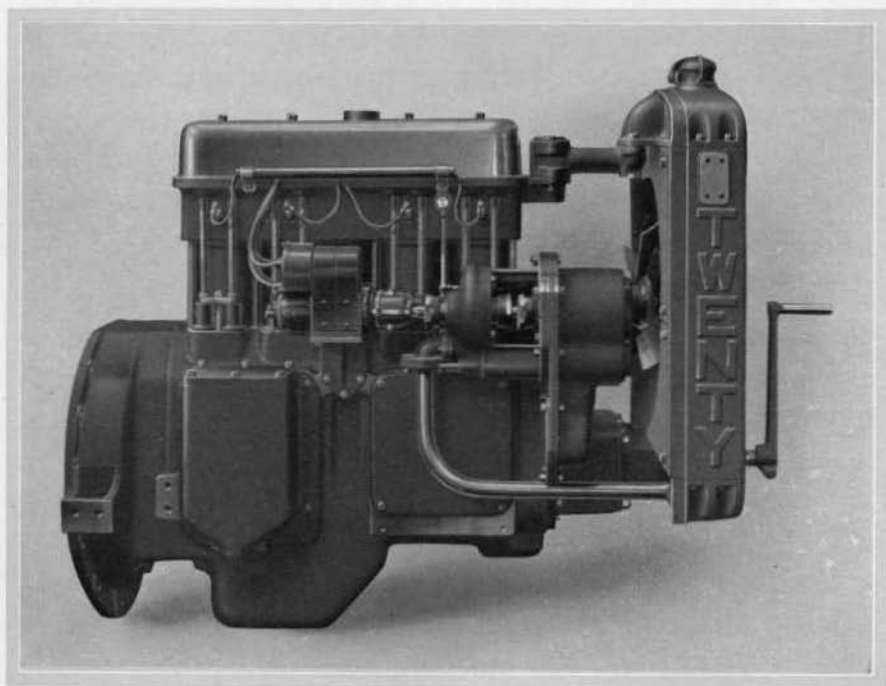

The right side of the "Caterpillar" Twenty Engine.



Speed The normal full load, governed speed of the engine is 1100 R.P.M. The cylinder bore is four inches and the piston stroke is five and a half inches.

Crank Case The crank case is a one-piece, barrel-type grey iron casting, with heavy oil sump cast integral. Unusual accessibility is an important feature. Large doors at the sides give easy access to the interior for adjustment or replacement of any of the main or connecting rod bearings, as well as the piston pins and pistons.

The crank case is bolted rigidly to the front end of the

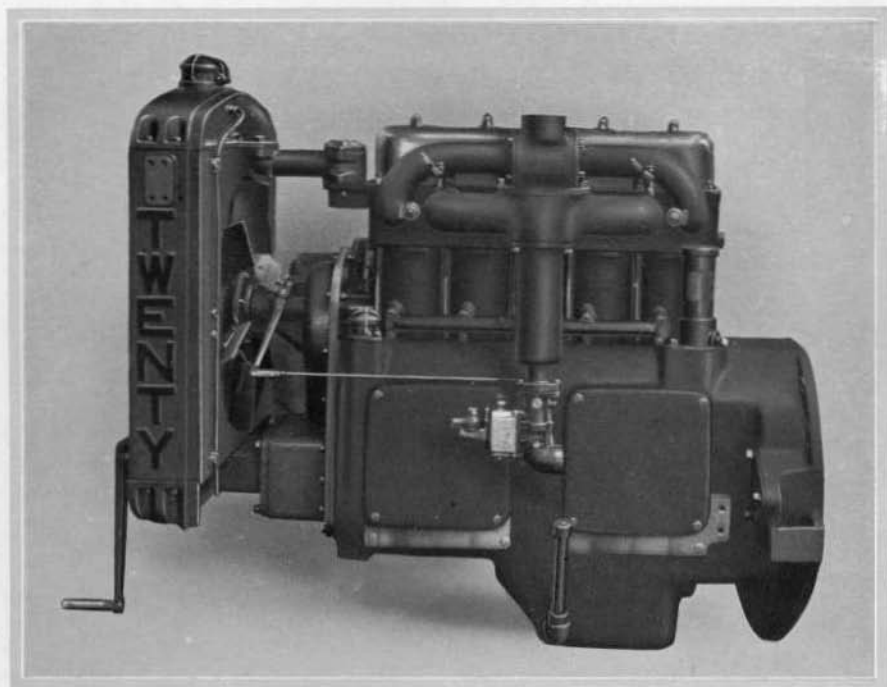

The left side of the "Caterpillar" Twenty Engine.



transmission case, the two units forming the main frame, a sturdy backbone for the entire machine.

Crank Shaft The crank shaft, $2\frac{1}{2}$ inches in diameter, is an unusually heavy drop forging, heat treated, so designed as to avoid any vibration period within the engine's operating range. A flange is forged integral with the shaft; to this flange the flywheel is bolted. Large oil passages are drilled from all main bearings to the crank pins.

The three large main bearings are so designed that the load on all bearings is uniform and also that proper alignment is maintained over a long period of service. The bearings are made in two parts; each bearing is composed of a babbitt-

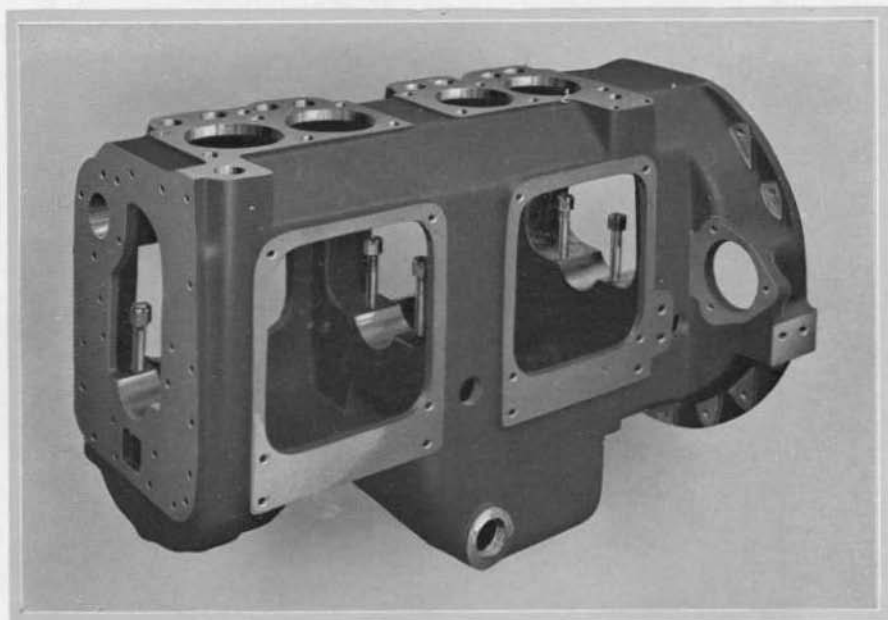

The Crank Case—a sturdy single casting. The large side openings make the entire interior easily accessible.

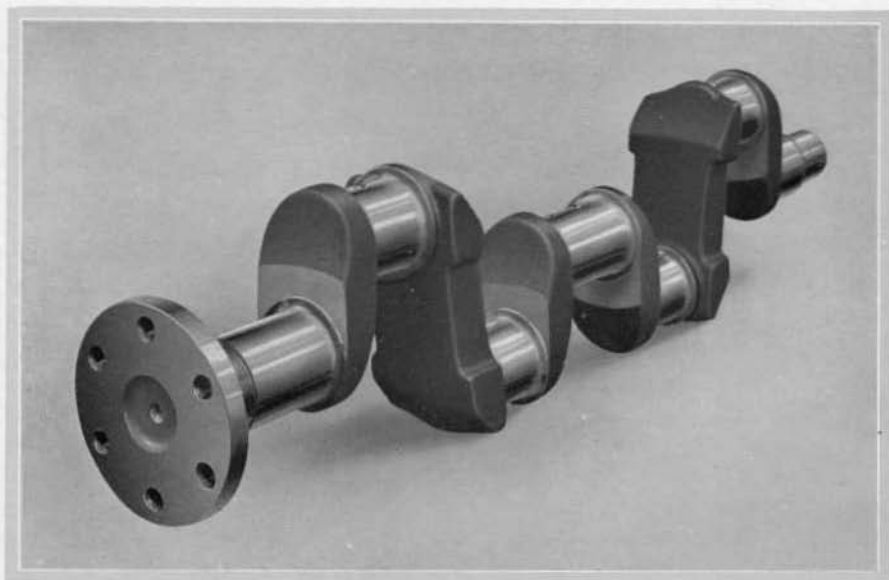

The 2 1/2-inch Crank Shaft. The flywheel flange is forged integral.

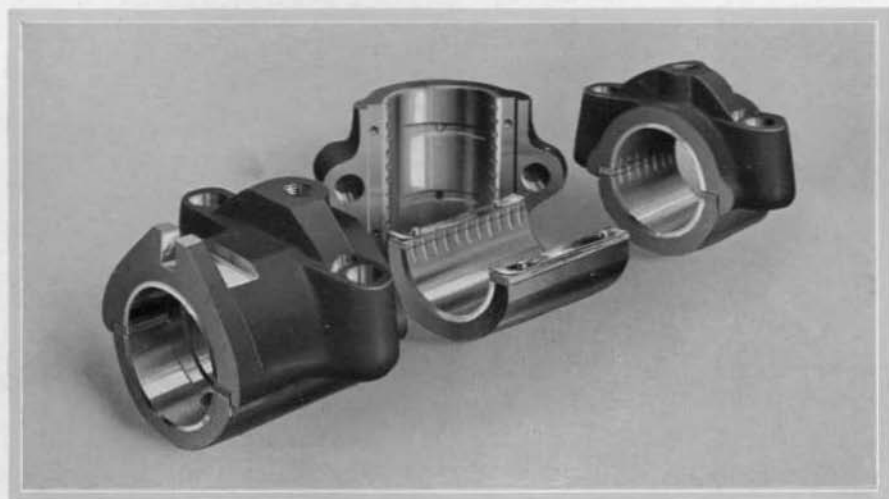

The Crank Shaft Main Bearings. After taking off the cap, the lower shell can be rotated on the shaft and removed without dis-assembling the engine.



lined steel shell and a drop-forged steel cap, also babbitt lined. Laminated babbitt-faced shims are provided for bearing adjustment.

At the rear end of the crank shaft is an oil thrower to prevent leakage under all working conditions. Crank shaft thrust is taken up by a special adjustable thrust bearing at the front end of the shaft.

The entire construction is so designed as to insure long life and freedom from trouble.

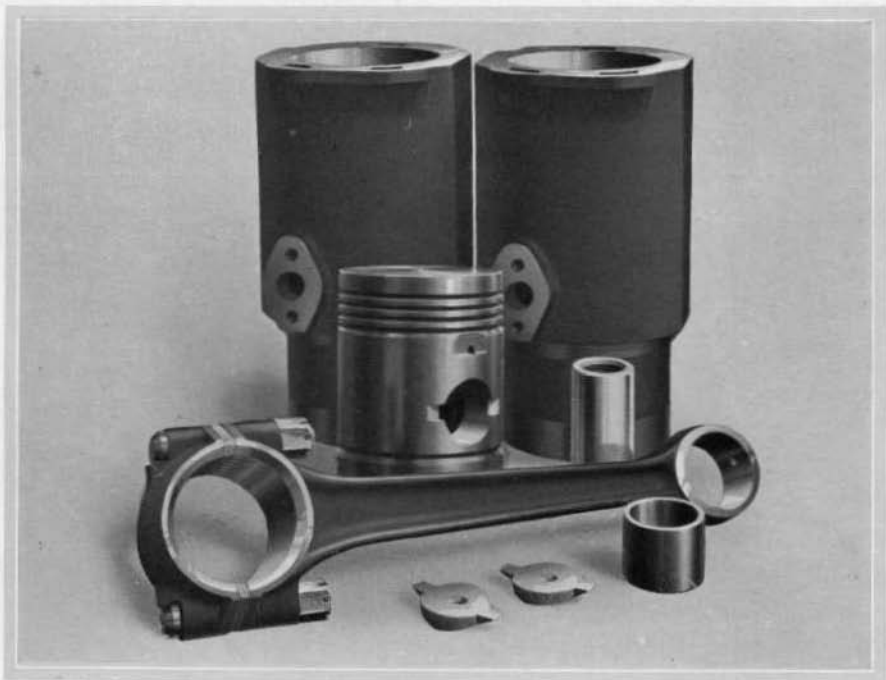

The Piston and Connecting Rod Assembly, and, in the background, two of the cylinders. Note in particular the aluminum plug piston pin retainers.



Pressure Lubrication The crank shaft and crank pin bearings, valve rocker arm shafts and fan shaft are lubricated by pressure oil system.

Connecting Rods Connecting rods are of I-beam cross-section, high-carbon, drop-forged steel, heat treated. The big-end bearing is anti-friction babbitt, cast directly into rod and cap. The small end is bushed with hard bronze bearing material. Both are lined up in a special aligning fixture before assembly. The connecting rods are strong, yet all unnecessary weight is eliminated, to avoid undue centrifugal force and prevent crank shaft vibration.

Pistons Pistons are grey iron castings. They have very long skirts, four compression rings and one oil ring. The piston pins float freely in both the piston and the connecting rod, and are retained by aluminum, die-cast plugs, pressed in the



The Cylinder Head of the Twenty Engine.



piston. These plugs prevent the ends of the pins from scoring the walls of the cylinder.

Cylinders Cylinders are cast singly, of a special grey iron mixture, and are provided with ample water jackets. Cylinder bores are machined to very close limits and honed to a smooth finish. Should one cylinder be accidentally scored or otherwise damaged, it can be replaced without the expense and delay of replacing the entire assembly.

Cylinder Heads Cylinder heads are also of special grey iron, cast en bloc, and provided with the most approved arrangement of water-cooling areas.

A dustproof, pressed-steel cover encloses the cylinder head and protects the rocker arm mechanism from dirt as well as forming an oil-tight compartment. The valve-in-head

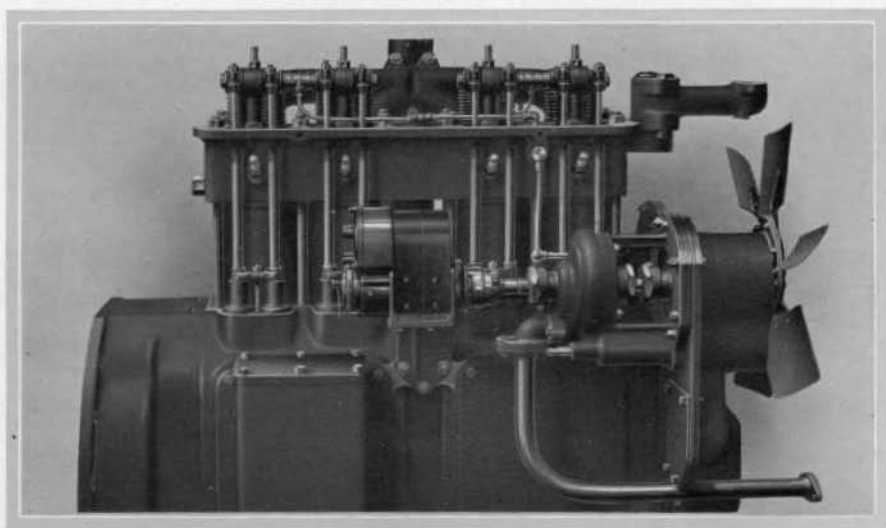

The Twenty Engine with cylinder head cover removed. The connections to radiator are all metal—no rubber hose.

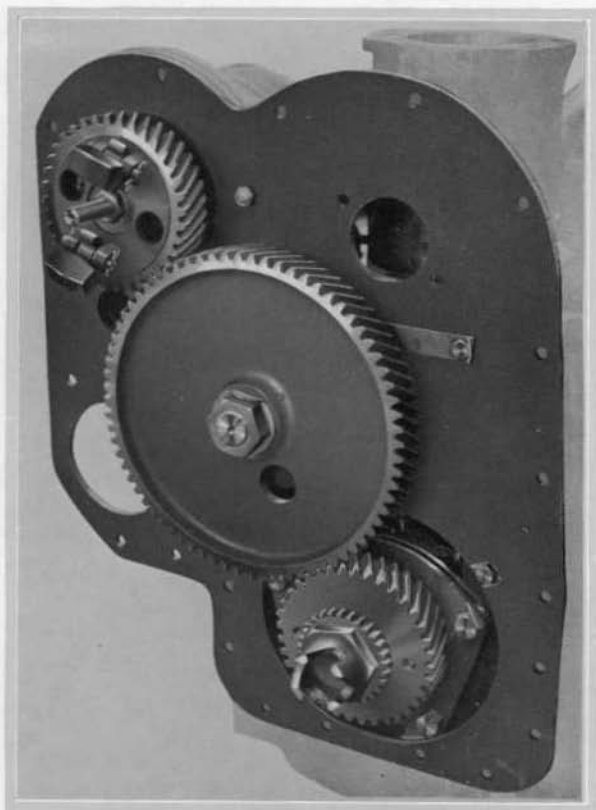

The Timing Gears, located at the front end of the engine, are drop forged from high carbon steel. The gears have wide faces and heavy pitch teeth. The fly-ball governor is mounted on the upper gear and shaft, which drives the water pump and magneto. Gears are marked to facilitate correct timing.

construction and removable head make for ready accessibility and facilitate the grinding of valves.

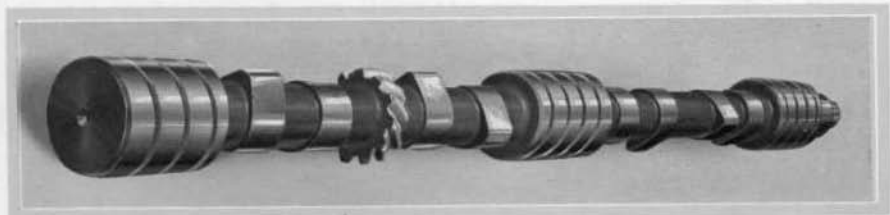

The Forged Cam Shaft has wide cams and unusually long and large bearing surfaces.



A sectional view from the front end of the Twenty Engine. Valve stem guides and lifter guides are removable. The upper end of the push rod is a hardened steel cup—the ball that rests in this cup is the lower end of an adjustable screw that provides the means of taking up lost motion in the valve mechanism.

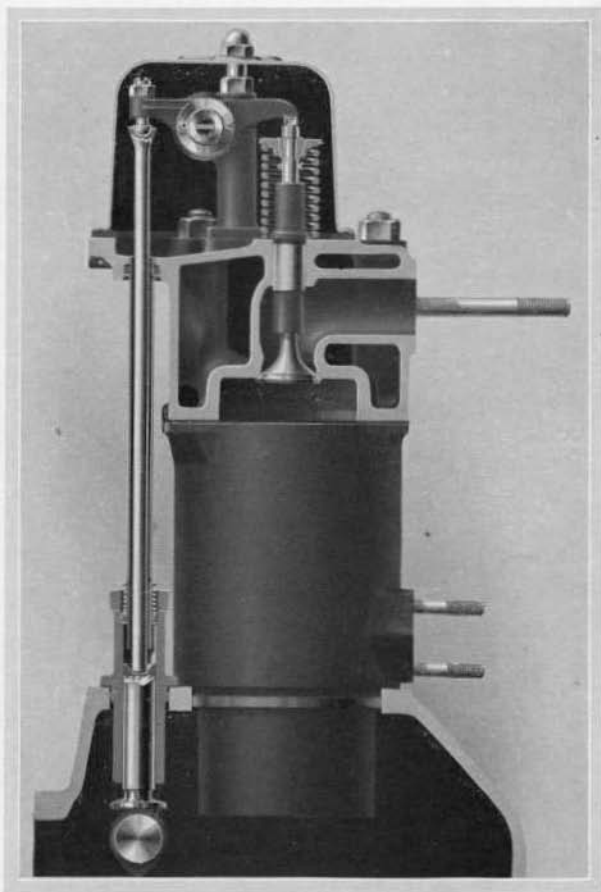

Timing Gears Timing gears are drop forged from high carbon steel, and have wide faces with helical-cut, heavy-pitch teeth. Lubrication is by pressure from the main oil line.

Cam Shaft The cam shaft is a large diameter forging of heat-treated steel, with cams and oil pump drive gear integral, all working surfaces carburized and ground. The shaft is provided with a special type of thrust bearing, of large capacity and positively lubricated. The line bearings for the shaft,

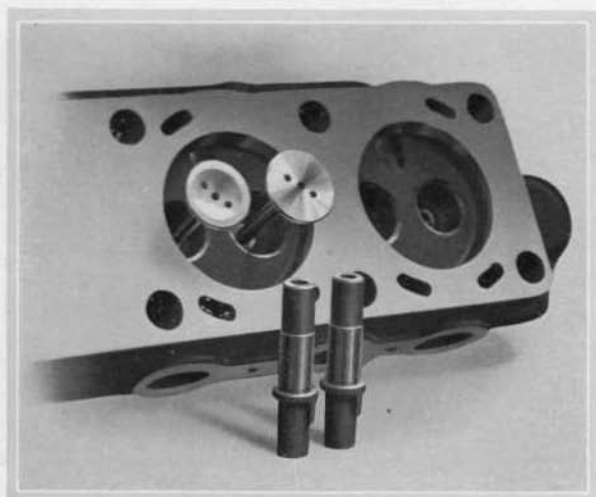

This shows a section of the Cylinder Head, Valves and Valve Stem Guides.

The valves are of alloy steel, machined and heat treated. Intake valves differ from exhaust valves in design and composition—each fitted for its particular service.

machined directly in the crank case, are unusually long. They are lubricated by throw-off from the crank shaft. The cams are wide, and so designed that the valves are held open for the correct period of time, and close gradually and easily, even when the operator fails to maintain accurate lifter adjustment.

Valve Mechanism The cams operate the valves through lifters, push rods and rocker arms. At the top of each push rod is a hardened steel cup which carries oil. In this cup, immersed in oil, rests the ball end of an adjustable screw in the end of the rocker arm.

The rocker arms are so designed that maximum valve lift is obtained with minimum cam lift.

The intake and exhaust valves are of special alloys of steel, and are machined and heat treated. All valves are fitted in removable stem bushings, which may be replaced when wear

THE "CATERPILLAR"



R" *TWENTY*

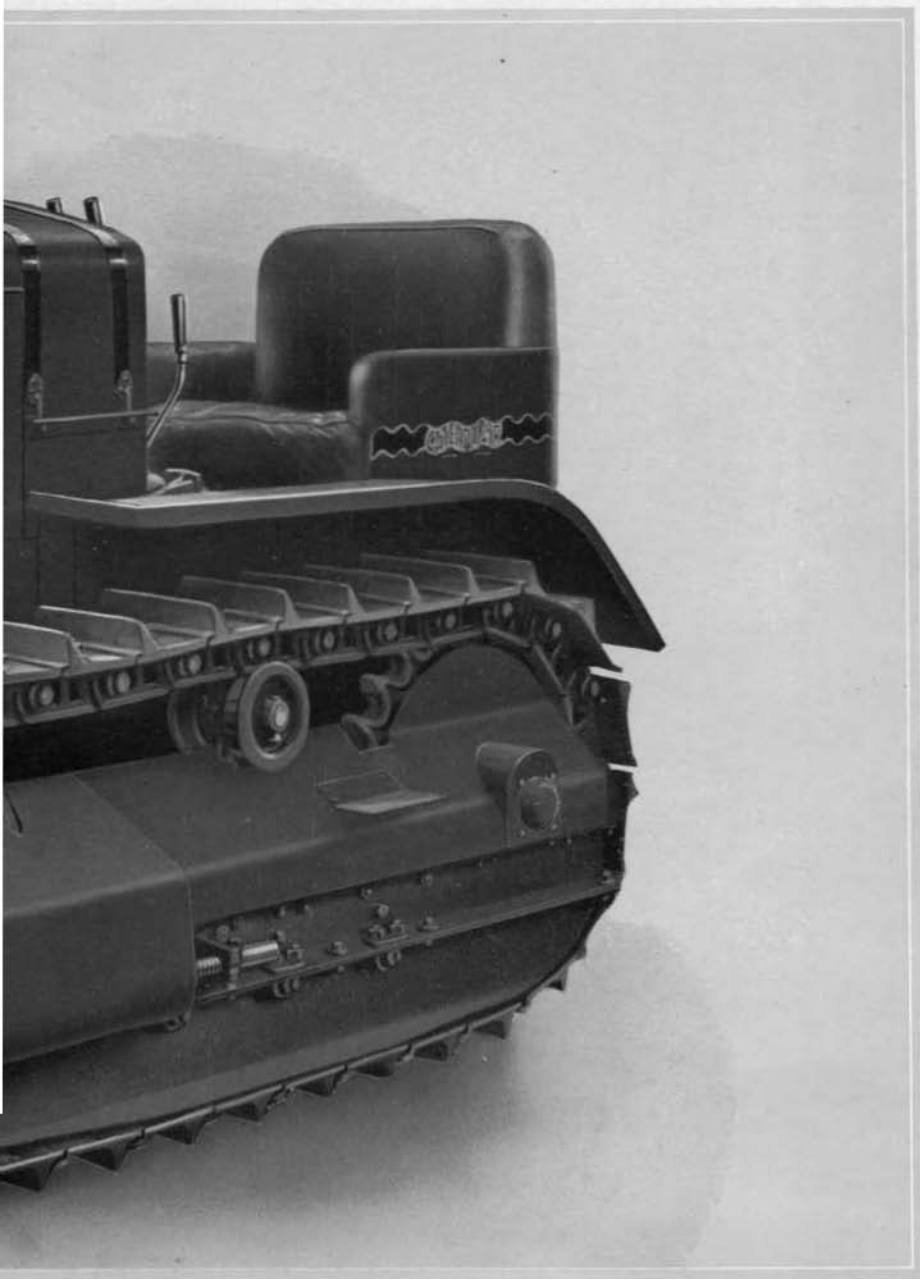

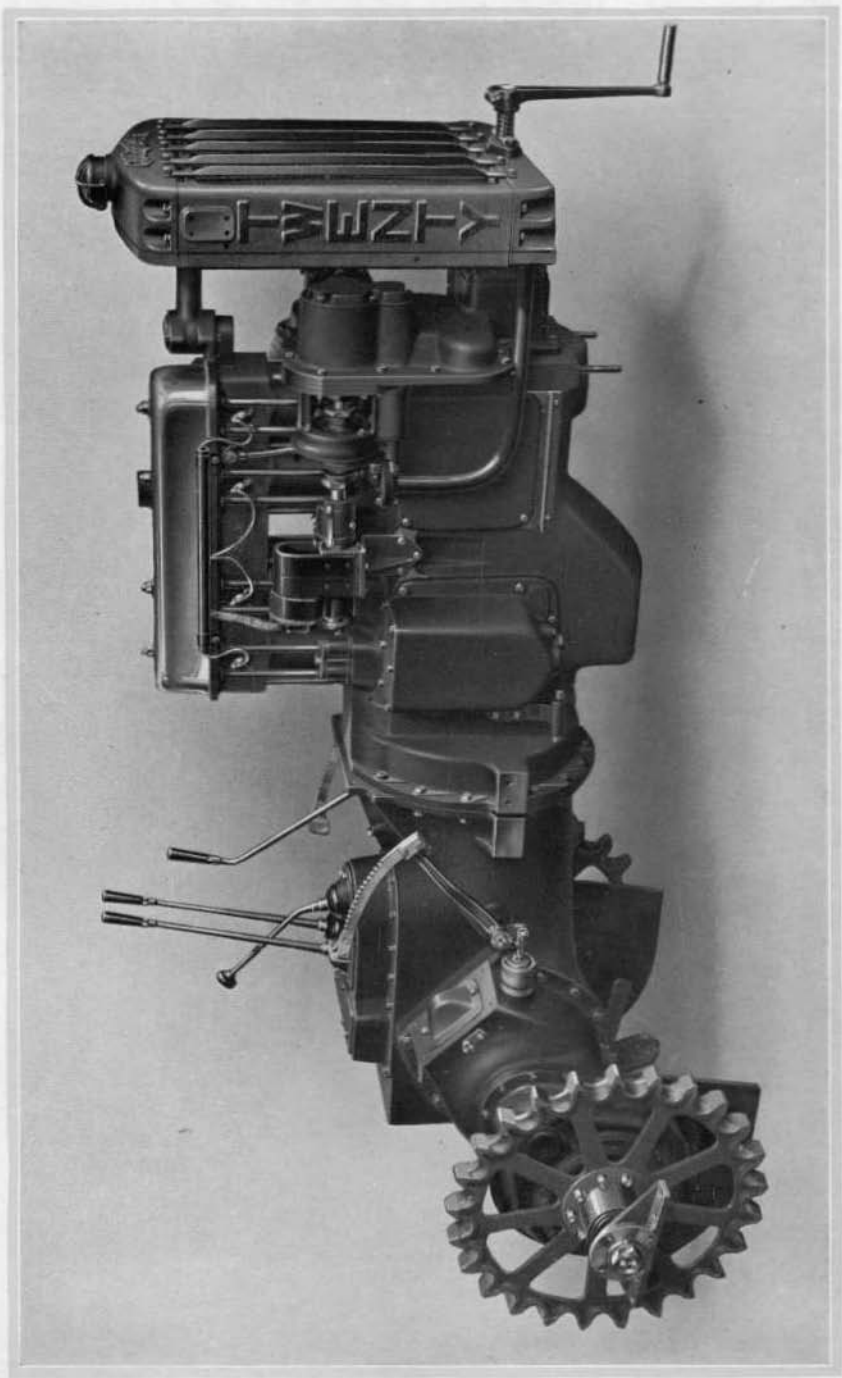

The Transmission Case and Crank Case bolted together to form the Twenty's main frame.



finally occurs. The valve heads may thus be kept in correct alignment with the seats.

Governor The governor is of the centrifugal, fly-ball type, enclosed at the front end of the engine in the timing gear compartment, and is so designed that it will control the engine at all speeds with close regulation. It is built as a unit with the water pump assembly and is lubricated by splash from the timing gears.

The engine speed is regulated by a hand throttle which acts directly on the governor spring in a manner that provides governor control at either high or low engine speeds.

Breather The breather is in effect a miniature air cleaner, containing oil-saturated fibre to catch dust that would otherwise enter the engine.

Air Cleaner From the foregoing descriptions it will be noted that every precaution is taken to enclose and protect all working parts of the tractor. "Caterpillar" engineers were among the "pioneers" in recognizing dust as a serious drawback to long life and efficient performance, and among the first to perfect means of protection, both from direct contact and from dust drawn with the air through the carburetion system.

The air cleaner is of the combination centrifugal and oil type, centrifugal action removing the heavier particles and oil-saturated curled wire "hair" collecting the finer dust. This cleaner has amazing efficiency—the value of such complete protection is apparent when it is considered that most tractors must operate in dust a large part of the time.

Oil Pump The oil pump, driven by spiral gears from the cam shaft, is of the duplex type. The pressure unit delivers oil



under pressure to the filter for cleansing, the clean oil then being distributed to the crank shaft and connecting rod bearings, the valve gear, timing gears and fan shaft bearings. The scavenge pump is provided to prevent oil from collecting in the front part of the engine. The pump has ample capacity for delivering lubrication through separate tubes, at lowest speed; surplus oil, at higher speeds, being returned automatically to the sump. The sump is so located that the rear of the crank case does not fill up on steep hills.

Oil Filter A case fitted to the right rear door of the crank case contains the oil filter, designed with two elements to thoroughly clarify the oil. Filters may be renewed or removed without breaking the oil line. Entrance is made through a cover in the top of the case.

Air Heater The air heater is located in the inlet manifold and controls the temperature of the mixture passing into the engine. The valve is operated from the driver's seat. This feature greatly facilitates "warming up" in cold weather and increases fuel efficiency.

Fuel Fuel is supplied from a heavy-gauge, sheet-steel tank, double-seamed at the joints, and located directly behind the engine, providing gravity feed to the carburetor. The capacity of the tank is 22 gallons. Fuel is filtered by a standard strainer. Gasoline is the recommended fuel, but provision is made for operation by kerosene when required. Alcohol may be employed as fuel by the use of a special carburetor. The heat control system is adequate to handle any standard fuel.

Carburetor The carburetor is of the plain tube type, so designed that it will operate on all grades encountered in service. The carburetor is of special design to meet the rugged



requirements of tractor service and, in particular, to exactly meet the requirements of the Twenty engine. The carburetor has an automatic economizing device to insure greatest possible fuel economy and engine efficiency. The throttle shaft and bearings are of hardened steel, sealed against the entrance of dirt at the bearings.

Ignition The standard electric system consists of a high tension magneto, equipped with an automatic impulse starting coupling. The magneto is in a readily accessible position on the water pump shaft, by which it is driven.

The entire ignition system is carefully protected against dust and the elements.

"CATERPILLARS" GRIN AT THE GRIT

— they don't complain about dust, silt and sand. "Caterpillar" engineers have won their long duel with the Dust Demon — effective seals, thorough air cleaners, scientifically heat-treated metal parts, close fits—all these have contributed to a splendid victory that makes "Caterpillars" long of life and notable for low maintenance cost.

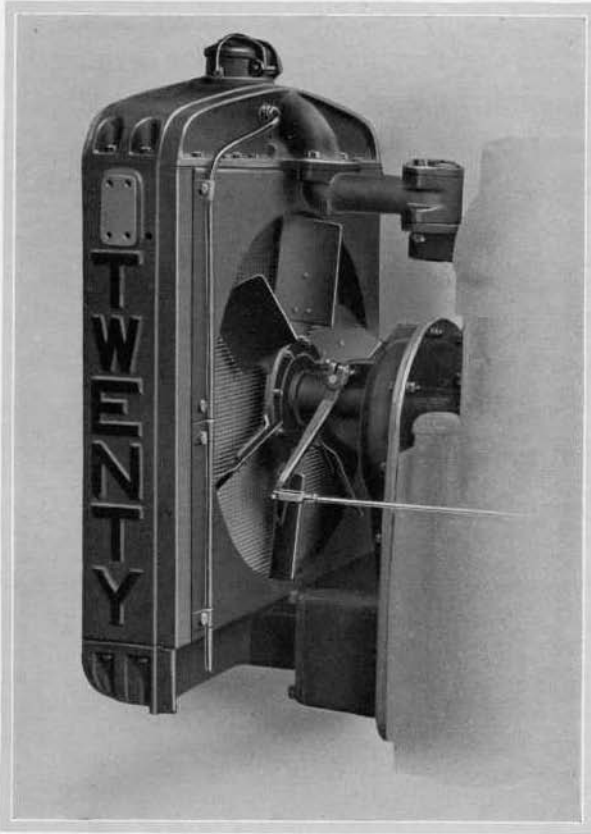

This shows several of the most important items in the cooling system—the radiator, fan and fan shroud, and thermostat housing. The thermostat is in the upper connection between radiator and engine. The fan drive includes a vibration dampener that also absorbs the shocks of starting and stopping.

Cooling System The cooling system consists of radiator, fan, thermostat, water jackets and connecting piping. The system is designed to keep the engine temperature low enough to avoid boiling, yet high enough to insure maximum fuel economy.

The radiator has cast iron upper and lower tanks and side plates and is of the vertical, flat tube, straight fin type, rigidly attached to the motor head at the top and to the crank case at the bottom. *There is no rubber hose in the assembly.*



Fan The fan is specially designed, 20 inches in diameter, with six wide, high-carbon steel blades, mounted on a heavy spider. Incorporated in the fan drive is a special type of vibration dampener which protects both fan and gears against shock loads.

The fan shaft runs in three bronze-back, babbitt-lined bearings, which are provided with pressure oiling from the engine's lubricating system.

The fan is driven by helical spur steel gears, all entirely enclosed and positively lubricated. This construction eliminates the expense of fan belts and the overheating resulting from the uncertainty of their operation.

Water Pump The water is circulated by a gear-driven centrifugal pump, designed for very rapid circulation. It is provided with a rust-proof alloy steel shaft and accessible stuffing boxes. A graphite-packed bearing for the pump shaft eliminates need of lubrication. The entire water pump assem-



A close-up view of the Water Pump Unit.

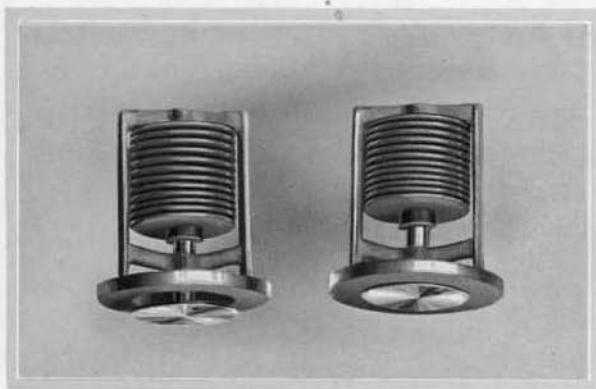

This picture shows the open and closed positions of the thermostat valve. Control of water circulation aids the obtaining of highest efficiency in engine operation.

bly forms an independent unit with the governor, thus insuring perfect alignment of these parts. The pump is not only unusually efficient, but also easily accessible. When the radiator is drained, all water automatically leaves the pump body, thereby eliminating the possibility of damage by freezing—an important safeguard in winter operation.

Water Jacket The engine has a specially designed water jacket system with passages properly narrowed at the hottest points to keep the water circulating past those points at highest velocity. The valve seats are completely encircled by water. Provision has been made to give equal protection at all vital parts in the engine.

Thermostat The engine has a specially designed water jacket controlled valve which maintains the water in the jackets at a minimum temperature of 160 degrees Fahrenheit. This insures low fuel consumption, rapid warming up and minimum crank case dilution. The thermostat control greatly facilitates the combustion of low-grade fuels.



Transmission

The word "transmission," as used herein, includes all parts involved in transmitting power from the engine to the tracks.

In the transmission are included many features which are chiefly responsible for the high efficiency in delivery of power. The principal reasons why the "Caterpillar" delivers so high a percentage of power to the drawbar are: elimination of differential gearing, the use of only three gear reductions in any speed, and the employment of anti-friction bearings throughout.

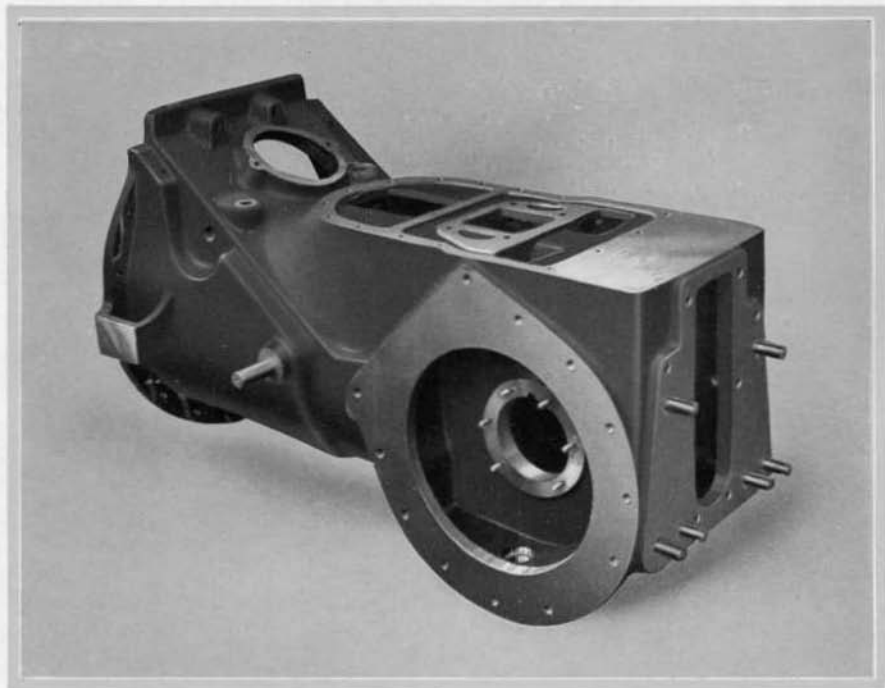

The Transmission Case, a heavy grey-iron casting.



Transmission Case The transmission case is a heavy grey-iron casting, strong and well reinforced by webs. The steering clutch housings are separate castings, that are bolted to the sides of the transmission case proper. The final drive housings are bolted to the steering clutch housings.

Flywheel Clutch The flywheel clutch is of the single dry-plate type, especially designed for long life and freedom from overheating.

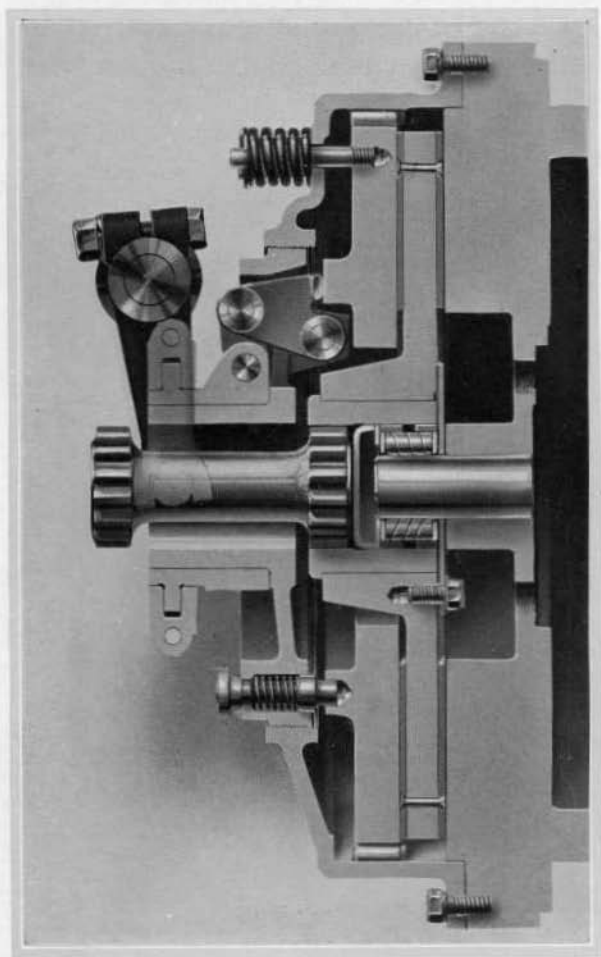

A sectional view of the Fly Wheel Clutch Assembly. This section gives some idea of the thickness of the clutch plates—the large volume of metal provides large capacity for heat absorption. This section also shows the coupling shaft that gives double universal action in the connection between clutch and transmission. The spring-engaged pin below the coupling shaft locks the clutch adjustment.



The driven member of the clutch is a heavy cast-iron plate, to both faces of which clutch facings are riveted. The driven member runs between the flywheel and another heavy cast-iron plate. The large volume of metal in the clutch plates gives big capacity for absorption of heat. The clutch design also provides a vigorous circulation of air to insure positive cooling. The clutch is mounted as a complete unit in the flywheel housing and is virtually a part of the engine assembly. Adjustment of the clutch is made in a very simple manner by pulling one pin and turning the disc. Clutch release is positive, powerful springs being provided to prevent any dragging.

The clutch drives the upper transmission shaft through the medium of a short, toothed coupling shaft that forms an all-metal, double universal joint requiring no lubrication. The

In this group are shown, at the top, the Upper Transmission Shaft and Gears and the Coupling Shaft that connects this shaft to the clutch; in the center, the Reverse Gear; at the bottom, the lower Transmission Shaft and gears. The bevel pinion is forged integral with the lower shaft.

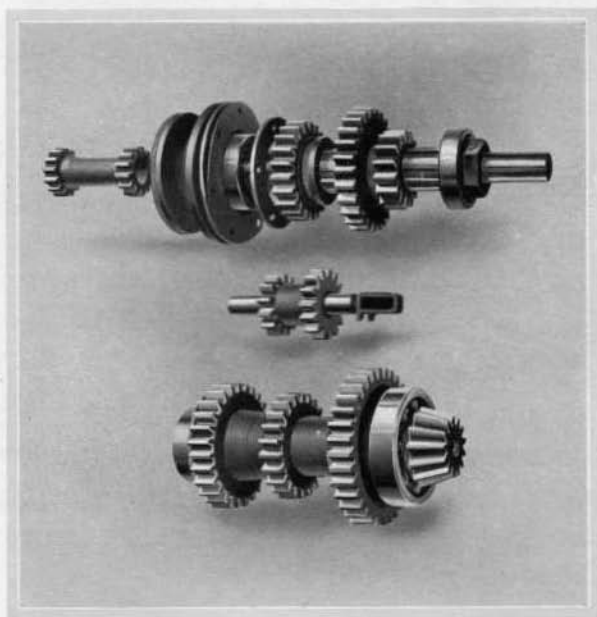

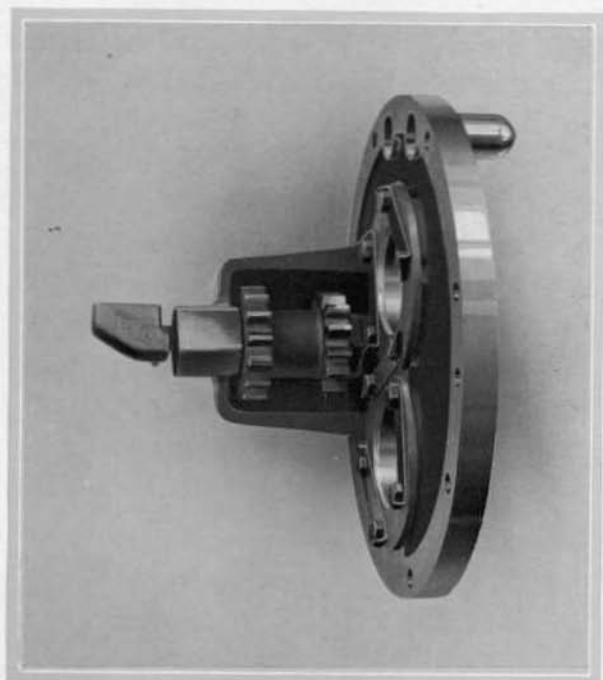

The Transmission Case End Plate. This plate, held by the dowels at the front end of the transmission case, carries the reverse gearing and holds the front bearings for the upper and lower transmission shafts—these are large size ball bearings. This plate, in addition to the other openings in the transmission case, gives unusually complete accessibility to the interior.

clutch pilot bearing is of the spiral roller type and likewise requires no lubrication.

Gears and Shafts Transmission of power from the engine through the clutch to the track is accomplished in three gear reductions — the first in the change speed gear set, the second in the bevel gear drive, and the third in the spur gear final drive.

All gears in the speed change are cut from high carbon, alloy steel drop forgings and are heat treated for maximum wear resistance. The bevel gear is cut from a solid, hammer upset forging of alloy steel. All transmission bearings are either single row, annular ball bearings or tapered roller bearings.

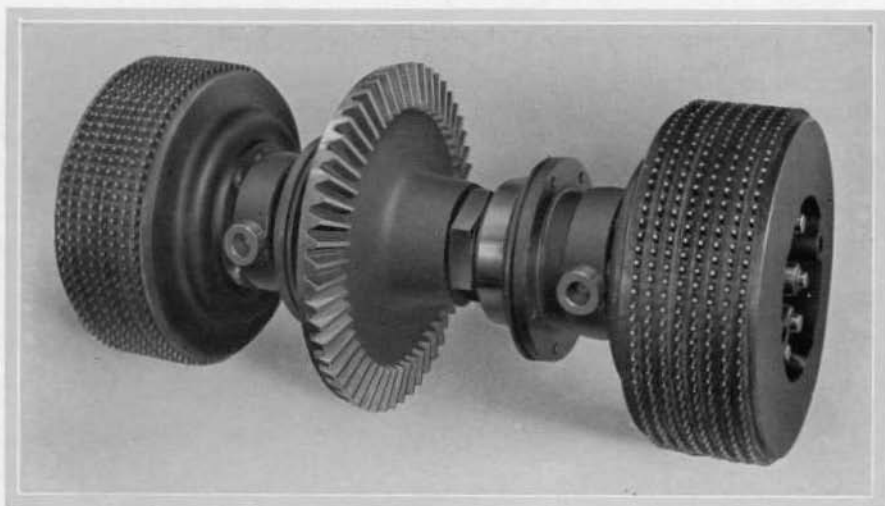

The Bevel Gear and Steering Clutches. These clutches operate dry—each clutch is controlled by its separate lever. The steering clutches are noteworthy for their easy control and positive engagement.

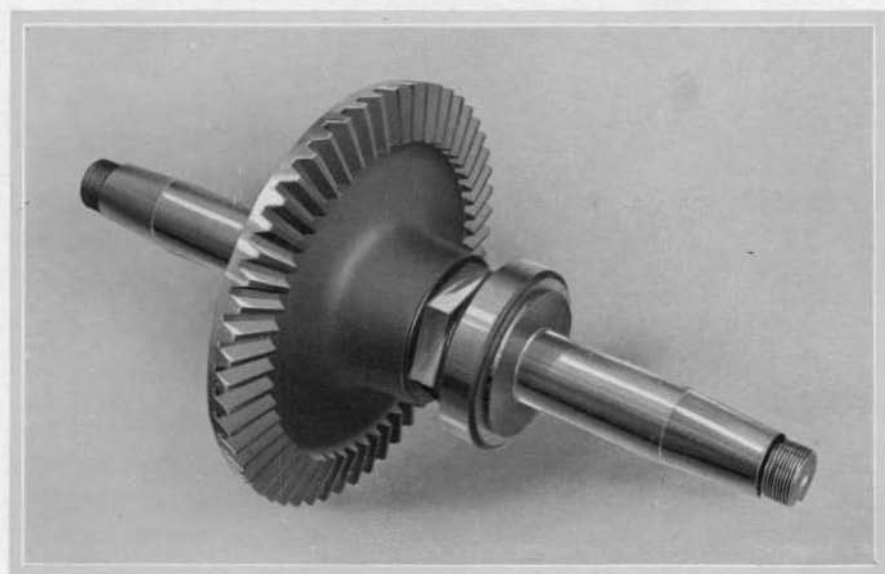

The Bevel Gear, a tapered and keyed fit on the bevel gear shaft.



The upper transmission shaft is cut from high carbon steel; the lower transmission shaft is a heat-treated upset forging of alloy steel, forged integral with the bevel pinion. From the bevel gear, power is transmitted through a heat-treated shaft, thence through the steering clutches to the final drive pinions.

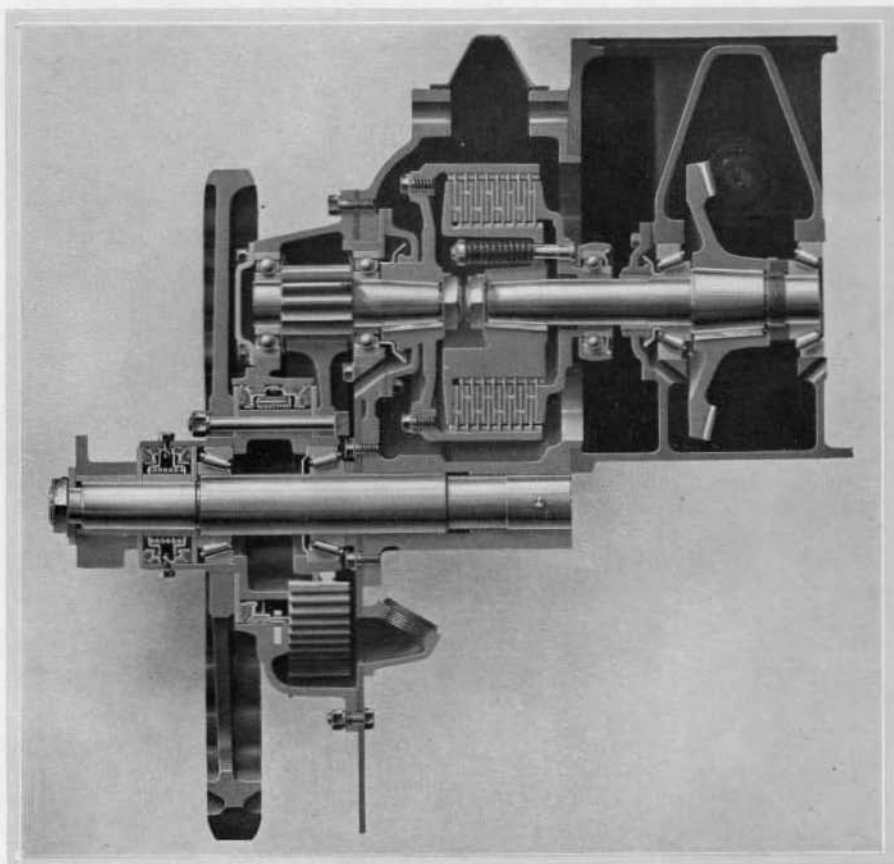

A sectional view of the Bevel Gear, one of the steering clutches, final drive pinion and gear and sprocket. Note the extensive use of anti-friction bearings and the thorough enclosure of moving parts.



Steering Clutches Control of the Twenty is accomplished through two independent steering clutches, operating dry, each controlling the operation of one track. These clutches are operated by two vertical levers conveniently placed and fitted with handles of a moulded composition, for greater comfort in extremely hot or cold weather.

The steering clutches form one of the most important units of the whole design. These clutches are so designed that they will "stand up" without undue wear, or bother to the operator.

The disengagement of one of the clutches diverts all of the power through the other clutch and turns the tractor in the direction of the released track. This design eliminates the complicated differential and provides simple, positive steering control. It gives exceptionally quick responsiveness, short-turning ability, and full power on the turns.

Additional control over the tracks when steering is provided by the steering clutch brakes, which are operated by independent foot pedals. This arrangement gives the operator complete control over his machine.

Either clutch, singly, or both together, can be released as desired. This is a great help when crossing ditches or other rough places, and under numerous other conditions. The driver can release the clutches with practically no effort.

Steering Clutch Brakes The foot pedals are provided with latches which may be used at the option of the operator to hold the Twenty on heavy grades. The brakes are big and husky, and work equally well in forward or reverse.

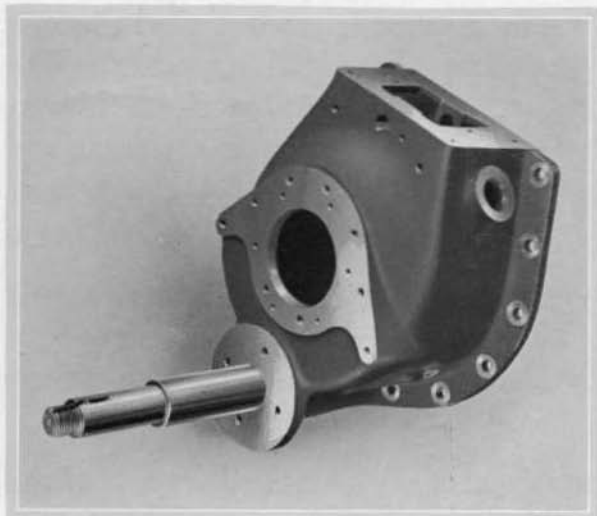

At the left is one of the Steering Clutch Housings. This case bolts to the side of the transmission case. Through the square opening at the top, the driver has access, from the driver's seat, to the steering clutch brake adjustment. Below are shown the final drive gear, pinion and sprocket.

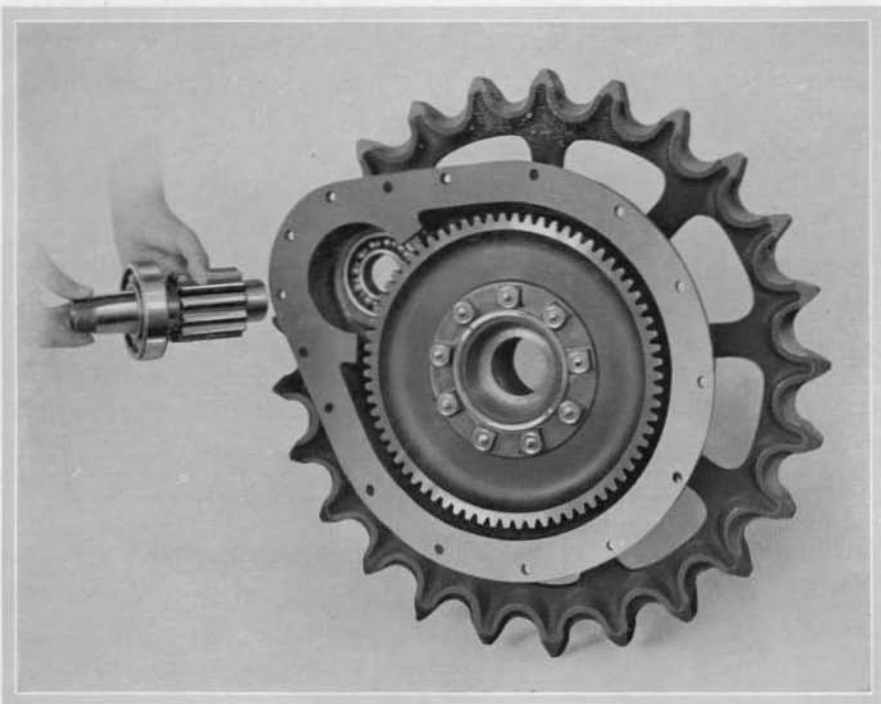



The brake levers are heavy, non-springing steel forgings. Brake adjustment may be readily made in a few seconds by removing small cover plates, which are accessible to the operator from the driver's seat. A leather boot encircling each brake lever where it enters the case is provided, to exclude dirt.

The gear shift lever is of the conventional ball and socket type, with an all-metal dirt guard.



This shows the Drive Sprocket and the case that encloses the final drive gear and pinion.

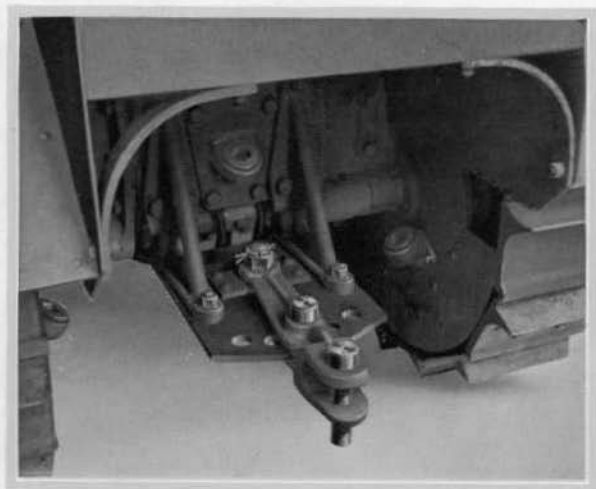

This picture shows the Drawbar, also the lubrication points for the transmission and final drive gear compartments. The plate directly above the drawbar is removable—in its place can be bolted the stationary drive for belt work, or a universal power take-off.

Final Drive Pinion The final drive pinions are high carbon, alloy steel, upset forged and heat treated; forged integral with the shaft. The bearings are ball bearings and unusually large. Pinions and bearings are lubricated by splash from oil in the main drive gear-housing.

Final Drive Gear The final drive gear is of high carbon alloy, forged, heat-treated steel, and is mounted, with the sprocket, on a heavy cast steel hub, the whole being held in assembly by nine large alloy steel bolts, heat treated. The hub turns on large tapered roller bearings mounted on the sprocket shaft.

Sprocket Shaft The sprocket shaft is of high carbon steel, heat treated, and ground to exact size.

Sprocket The sprocket is cast from high carbon steel, heat treated for strength and resistance to wear and distortion, then quenched under tremendous hydraulic pressure to prevent warping.



Miscellaneous Equipment

Seat The comfort of the operator has been thoughtfully considered in the design of the tractor. A wide, well-cushioned seat is bolted above the transmission case, so that the driver is within easy reach of levers, foot pedals and inlet manifold heat control.

Fenders Heavy steel fenders are standard equipment, giving maximum protection to the operator and also forming a deck upon which cab or summer top may be mounted without disarranging any parts.

Tools Adequate tool equipment is furnished, ample in variety to make changes and adjustments in the field. The tools are carried in a container under the seat cushion.



Specifications

- ENGINE—Bore, 4"; stroke, $5\frac{1}{2}$ "; R.P.M., 1100.
- VALVES—Exhaust, head diameter, $1\frac{23}{32}$ "; stem diameter, $\frac{7}{16}$ ". Inlet, head diameter, $1\frac{29}{32}$ "; stem diameter, $\frac{7}{16}$ ".
- CRANK SHAFT—Diameter, 2.50".
- CAM SHAFT—Bearings, diameter, 2.25".
- PISTONS—Diameter, 4". Length, 5.25". Rings, $\frac{1}{8}$ ".
- PISTON PINS—Diameter, 1.50".
- FAN—Blades, 6. Fan diameter, 20".
- BRAKES—Drum diameter, $11\frac{5}{8}$ ". Band width, 3".
- FUEL—Gasoline. (In countries where gasoline is unobtainable or where its price is unduly high in comparison with other locally obtainable fuels, distillate, kerosene, alcohol, etc., can be used. Information regarding the use of such fuels furnished on request.)
Fuel tank of 22 gallons capacity.
- FLYWHEEL CLUTCH—Drives upper transmission shaft through all-metal double universal connection. Two friction surfaces. Clutch plates, 14" diameter. Friction surface area, 115 sq. in.
- TRANSMISSION—Selective gear type, three speeds forward and one reverse. Single reduction in all forward speeds.
- STEERING—No. of plates in each clutch, 16. No. of springs, 8. Diameter moulded lining, $10\frac{1}{4}$ ". Area friction surface each plate, 44 sq. in.
- FINAL DRIVE GEARS—Pitch, 5. Diameter assembling bolts, $\frac{5}{8}$ ". No. of bolts, 9.
- SPROCKET—No. of teeth, 25. Diameter of face, $2\frac{1}{4}$ ". No. of bolts, 9. Diameter of bolts, $\frac{5}{8}$ ".
- TRACK—Width of track shoe (standard), 11". Height of integral grouser, $2\frac{1}{4}$ ". Diameter of track shoe bolts, $\frac{1}{2}$ ". Diameter of track pin, $1\frac{5}{16}$ ". Diameter of track pin bushings, 2".
- GREASE PUMP—Capacity, 25 lbs.
- RATINGS—Engine speed, 1100 R.P.M. Drawbar horsepower, 20. Belt horsepower, 25.
- SPEEDS—Low, 1.79 M.P.H. Intermediate, 3.07 M.P.H. High, 4.67 M.P.H. Reverse, 2.26 M.P.H.



DIMENSIONS—Over-all length, 115.5". Over-all width, 61". Over-all height, 60.5". Tread, 42". Ground clearance under transmission, 12". Drawbar height above ground, 15 $\frac{3}{4}$ ".

NET WEIGHT (Approximate)—7,000 lbs.

SHIPPING WEIGHT (Approximate)—7,500 lbs.

Special Equipment

Various items of special equipment to meet a wide range of requirements are available for installation either at the "Caterpillar" plants or in the field.

Reference has already been made to the fact that special track shoes may be ordered in place of the standard 11-inch shoe. Following is a list of other special equipment and the service for which intended:

SPARK ARRESTER—A spark arrester offers maximum protection against the possibility of sparks coming from the exhaust.

FRONT PULL HOOK—A front pull hook is often useful for pulling loads in reverse gear.

LIGHTING EQUIPMENT—Powerful headlights, with brackets and necessary wiring, can be furnished applied at the plant, or boxed for field installation. Bracket bolt holes are tapped into radiator side plates and in the fenders at the rear of the tractor, to enable the owner to locate lights to suit his convenience. Current for the lighting system can be furnished either direct from a generator, or by a generator and storage battery system.

STATIONARY DRIVE UNIT—For belt work, a stationary drive can be attached to the rear of the transmission case. This unit connects directly with the upper transmission shaft.

POWER TAKE-OFF—For use with various equipment that is designed to be operated by, as well as pulled by, a tractor, the Twenty can be equipped with power take-off at either the front or rear.

SUMMER TOP AND CLOSED CAB—Summer top and cab equipment for the Twenty is of the quickly convertible type. The summer top consists of angle iron frame and curved top over the driver's seat. This is easily



converted into a completely enclosed cab by the addition of sides and doors or curtains.

ELECTRIC STARTER—An electric starter, with a floor button, starting motor and starter flywheel ring, can be installed. It is best to order this equipment attached at the "Caterpillar" plants; but starter ring shrunk upon the flywheel, together with motor and accessories, can be supplied for field installation. The use of an electric starter, of course, necessitates that the tractor also be equipped with generator and battery, which can be used both for the starter and the lights.

STREET PLATES—For conditions that make the use of a smooth track surface necessary or desirable, street plates can be furnished. These plates bolt to the standard shoes and provide a flat ground contact without projecting grousers or bolt heads.

MUFFLER—The Twenty can be equipped with a muffler on the exhaust.

ODOMETER—To aid those tractor users who desire to keep accurate work records or cost records, the Twenty can be fitted with an odometer, which registers distance traveled, in miles.

ALCOHOL CARBURETOR—A special carburetor for use when alcohol is used as fuel.